

HEATIT Z-DIM

Firmware 1.0

01.09.2019

Ver 2019-B

Installers manual



Norwegian version
Download
manuals.thermo-floor.no
www.thermo-floor.no

heatit



NB! DIMMING

Lighting management may be challenging, and we recommend checking the compatibility of different units before installation. We are happy to answer any questions.

STATEMENT REGARDING PRODUCTS FROM MULTIPLE MANUFACTURERS Please read this before installation

This device may be used with all devices certified with the Z-Wave Plus certificate and should be compatible with such devices produced by other manufacturers. Every primary controller is different depending on the manufacturer, their target audience and intended use/application. Please review the functionalities implemented by the primary controller you intend to use with our Z-Wave Plus certified device to ensure that it provides the necessary controls to take full advantage of our product's capabilities.

QUICK START

1. Switch off the mains voltage (disable the fuse).
2. Open the wall switch box.
3. Connect according to the wiring diagram as shown in chapter 6 "Installation & wiring" or on the backside of the dimmer.
4. After verifying the connections, switch on the mains voltage.
5. Set the primary controller in add mode (security/non-security).
6. Press the main button on dimmer 6 times in a rapid sequence.
Heatit Z-DIM is now included in your Z-Wave network.

1. COMPATIBILITY

Rotary dimmer for many types of light sources. It dims LED-bulbs from 1-200VA, 230V halogen and incandescent bulbs, dimmable LED-drivers and electronic transformers. Do not use the dimmer for inductive loads as fluorescent lighting, fans or linear transformers. Electronic equipment must be installed by an authorized electrician.

Heatit Z-Dim is a trailing edge dimmer and consequently very well suited for LED.

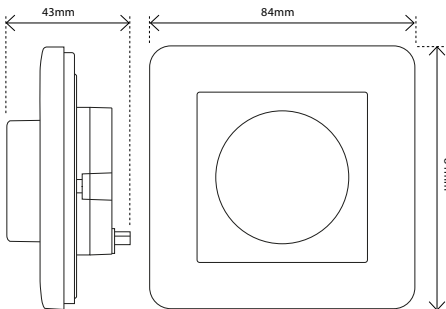

2. FACTORY RESET

By pressing and holding the main button for 20 seconds, the dimmer will perform a complete factory reset. The connected light source will blink once and go in the "OFF" state if successfully reset. **NB!** Please use this procedure only when the primary controller is missing or otherwise inoperable.

3. BEHAVIOR WITHIN THE Z-WAVE NETWORK

This product can be operated in any Z-Wave network with other Z-Wave certified devices from other manufacturers. All non-battery operated nodes within the network will act as repeaters regardless of the manufacturer to increase the reliability of the

network. On delivery, the device does not belong to any Z-Wave network. The device needs to be added to an existing network to communicate with the devices of this network. Devices can also be removed from a network. Both adding and removing processes are initiated by the primary controller of the Z-Wave network.

This primary controller will enter a mode for adding or removing devices. Please refer to your primary controller manual on how to turn your primary controller in to add or remove mode. The device can only be added or removed from the network if the primary controller is in add/remove mode. When the device is removed from the network, the device will revert to factory default settings.

4. ADD/REMOVE

Please refer to your primary controller manual on how to enter add/remove mode. The device can only be added or removed from the network if the primary controller is in add/remove mode.

When the primary controller is set to add/remove modus press the main button on the dimmer 6 times in a rapid sequence.

If the device already belongs to a network, follow the removing process before adding it in your network. Otherwise, the adding of this device will fail. When the device is removed from the network, the device will revert to factory settings.

5. CONTROL

Increase / decrease

On / Off

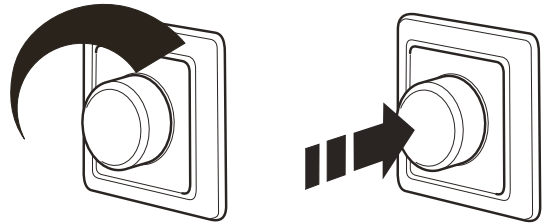

6. INSTALLATION & WIRING

Installation must be done by a qualified electrical installer by following the National Building codes. Before installation, disconnect any power to the dimmer mains. During the installation process, power to the dimmer must be disconnected AT ALL TIMES!

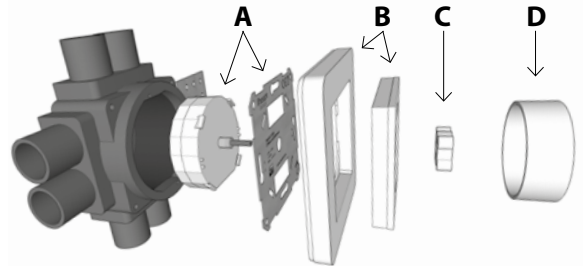

1. Disconnect the power.
2. Connect the live to the dimmer terminal "L".
3. Connect the neutral to the dimmer terminal marked "N".
4. Connect the neutral to the load terminal marked "N".
5. Connect the load terminal marked "L" to the dimmer terminal marked (see wiring diagram).
6. Install the dimmer (A) in the wall box. Make sure that no wires are pinched.
7. Attach the cover (B) with the supplied nut (C).
8. Attach the button (D) with a simple push.

To use the **multiway function** (stairway function) a 230VAC rated momentary switch can be connected as follows:

9. Connect the live to the toggle switch terminal marked "L".
10. Connect the toggle switch terminal marked to the dimmer terminal marked "S" (see wiring diagram).

Wiring diagram

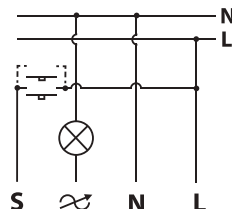

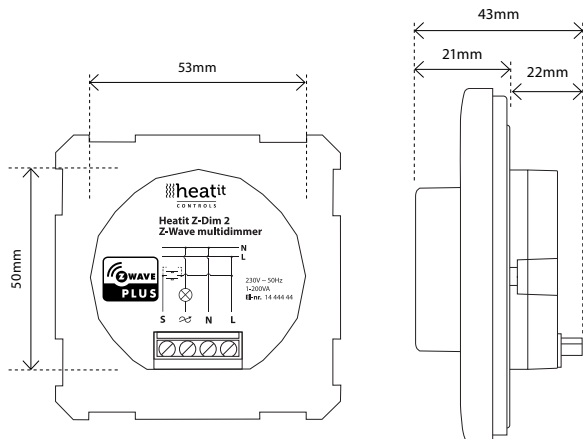

The Heatit Z-Dim switches off if the load exceeds the maximum level. For the dimmer to work correctly again, the error must be corrected and the dimmer turned off and on one time.

STARTUP

AFTER CONNECTING THE POWER TO THE MULTIDIMMER FOR THE FIRST TIME, ALL PARAMETERS WILL HAVE DEFAULT SETTINGS.

7. MULTIWAY SWITCH FUNCTIONALITY (stairway function)

Heatit Z-Dim has an integrated stairway function. This is used when a user would like to control the lights from more than one location.

To use multiway switching, connect the product as described in Paragraph 6 "Installation & Wiring". Use up to 2,5mm² wire according to the load.

N	Power connection (Neutral) 230V
L	Power connection (Live) 230V
LO	Load connection
S	Multiway switch function (Momentary switch)

8. POWER METERING

The Heatit Z-Dim has functionality to calculate power consumption. To enable this function, Parameter 1 "Connected load" should have a value greater than 0. This is an estimated value, therefore power consumption accuracy depends on load estimation.

1. Estimate the load value (Watt) connected to the Heatit Z-Dim.
2. Use this value in Parameter 1.

Heatit Z-Dim can report accumulated (kWh) and instant (Watt), or only instant (Watt) power consumption. The report time interval can be altered by Parameter 9.

9. CALIBRATION

Heatit Z-Dim may need to be calibrated after installation. To get the Heatit Z-Dim dimmer calibrated the following procedure should be performed after installation.

1. Add the dimmer to your Z-Wave network as described in Paragraph 4 "Add/Remove".
2. Turn the wheel counterclockwise to get the lowest brightness level.
3. Adjust Parameter 2 "Minimum Dim level" according to your needs.
4. Turn the wheel clockwise to get the highest brightness level.
5. Adjust Parameter 3 "Maximum Dim level" according to your needs.

10. SCENE CONTROLLER

Heatit Z-Dim supports Central Scene Command Class. This allows you to run various scenes defined in the primary controller.

Altering Parameter 5 and 6 will change the functionality of the Heatit Z-Dim.

Action	Attribute
2 clicks	Key Pressed 2 times
3 clicks	Key Pressed 3 times
4 clicks	Key Pressed 4 times
5 clicks	Key Pressed 5 times

11. OPERATING THE DEVICE

Heatit Z-Dim does not support the Multi Channel Command Class (Multichannel encapsulation). The device contains 3 association groups.

For further information, see Paragraph 15 "Association Groups".

Supporting Command Classes

Besides the mandatory command classes, Heatit Z-Dim has support for following command classes:

• Basic Command Class

Sending **Basic Set** command to the dimmer will change the level of the multilevel switch. The Basic Command Class values are mapped to the Multilevel Switch Command Class. When powering the OFF using button, the value 0 is sent (0x00). When powering the ON using button, the value 255 is sent (0xFF). When using the rotary encoder, the values 1 - 99 is sent (0x01-0x63).

• Binary Switch Command Class

Sending **Binary Switch** command to the dimmer will change the state of the device (ON / OFF). If changing Parameter 7 this function may be altered.

• Multilevel Switch Command Class

Sending **Multilevel Switch** command to the dimmer will change the level of the multilevel switch.

12. SECURITY

The S2 security enhances Z-Wave Plus with an additional layer of AES 128-bit encryption of the wireless Z-Wave communication to prevent hacking and man-in-middle attacks of the home network. The Heatit Z-Dim supports S2 and has a Z-Wave DSK QR-code label that can be used when the module is included to the Z-Wave home network. The including primary controller will ask for a 5-digit code, which can be identified beneath the QR-code, and will then ask to confirm the rest of the code that is contained in the QR-code.

The Z-Wave DSK can be found in the QR-Code and is located in 3 locations:

1. Box of the product.
2. On physical product, placed on the metal frame.
3. On the PCB.

13. NODE INFORMATION FRAME

The Node Information Frame is the business card of a Z-Wave device. It contains information about the device type and the technical capabilities. The add and remove procedure of the device is confirmed by sending out a Node Information Frame. Besides this, it may be necessary for certain network operations to send out a Node Information Frame.

14. ASSOCIATIONS

Z-Wave devices control other Z-Wave devices. The relationship between one device controlling another device is called association. In order to control a subordinate device, the controlling device needs to maintain a list of devices that will receive controlling commands. These lists are called "Association Groups". They are always related to the specific event triggered (e.g. sensor reports). In case the event occurs all devices stored in the respective association group will receive a common wireless command.

SCENARIO 1

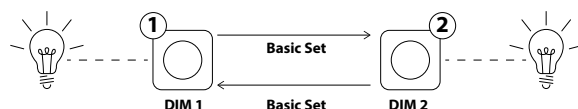

Scenario 1A Associate two Heatit Z-DIM dimmers.

Expected behavior

1. "DIM 1" will control lights attached to both "DIM 1" and "DIM 2".
2. "DIM 2" will control lights attached to both "DIM 2" and "DIM 1".

Required configuration

1. "DIM 1" needs the following setup:
 - a. Association using "**Basic Set**" from Association Group 2 to "DIM 2".
2. "DIM 2" needs the following setup:
 - a. Association using "**Basic Set**" from Association Group 2 to "DIM 1".

SCENARIO 2

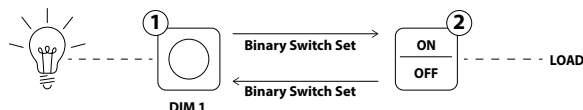

Scenario 2A Associate Heatit Z-DIM with a Binary Switch device.

Expected behavior

1. Turning ON/OFF "DIM 1" will turn "Binary Switch Device" ON/OFF.
2. Turning ON/OFF "Binary Switch Device" will turn "DIM 1" ON/OFF.

Required configuration

1. "DIM 1" needs the following setup:
 - a. Association using "**Binary Switch Set**" from Association Group 3 to "Binary Switch Device".
2. "Binary Switch Device" needs the following setup:
 - a. Association using "**Binary Switch Set**" from Association Group 3 to "DIM 1".

15. ASSOCIATION GROUPS

MULTI LEVEL SWITCH DEVICE	DESCRIPTION
Group 1 Lifeline	Lifeline. (Normally used by the Z-Wave Controller) Sends: - Multilevel Switch Report - Meter Report - Device Reset Locally - Central Scene Notification Max. nodes in the group: 8
Group 2 Dimming level	- Basic Set Basic Set is usually used to control other dimmer devices. Max. nodes in the group: 8
Group 3 State of Device ON/OFF	- Binary Switch Set Binary Switch Set is usually used to control other ON/OFF devices. Max. nodes in the group: 8

Setting and Removing Associations

Associations can be assigned and removed via Z-Wave commands. Please refer to the primary controller user manual.

16. CONFIGURATION PARAMETERS

Z-Wave products are supposed to work *out of the box* after adding, however, certain configurations of a device can alter the functionality to better serve the users needs or unlock further enhanced features.

After a change in any parameter, the dimmer will turn ON using the dimming level value from Parameter 10 "Power restore level".

Parameter 1, Parameter Size 1. Connected Load.
The parameter defines the value of connected load. Refer to Paragraph 8 "Power Metering".

VALUE	DESCRIPTION
0	Not configured (Default)
1 - 200	1-200 Watts connected load

Parameter 2, Parameter Size 1. Minimum Dim level.
The parameter defines the lowest dimming level of the dimmer. The value must be lower than parameter 3 "Maximum Dim Level".

VALUE	DESCRIPTION
1 - 98	1% - 98% Default is 20 (20%)

Parameter 3, Parameter Size 1. Maximum Dim level.
The parameter defines the highest dimming level of the dimmer. The value must be higher than parameter 2 "Minimum Dim Level".

VALUE	DESCRIPTION
2 - 99	2% - 99% Default is 85 (85%)

Parameter 4, Parameter Size 1. Total steps.
The parameter defines how many steps it should take to dim from minimum to maximum dim level (One round = 20 steps).

VALUE	DESCRIPTION
5 - 255	5-255 steps. Default is 15 (3/4 round)

Parameter 5, Parameter Size 1. Double press function.
The parameter defines the double press functionality.

VALUE	DESCRIPTION
0	Central Scene notification (Default)
1	Dim to highest level

Parameter 6, Parameter Size 1. Scene controller.
The parameter enables scene controller.

VALUE	DESCRIPTION
0	Disabled
1	Active (Default)

Parameter 7, Parameter Size 1. Switch ON level.
The parameter defines the dimming level when restored from the OFF state by push button.

VALUE	DESCRIPTION
0	Restores last dim level (Default)
1 - 99	1% - 99%

Parameter 8, Parameter Size 1. Dimming Duration.
The parameter defines how long it takes to dim to the desired level. Note! Only Multilevel Switch Command Class is affected by this parameter.

VALUE	DESCRIPTION
0	Disabled
1 - 127	Duration in seconds (1 - 127 seconds. Default is 1)
128 - 255	Duration in minutes (1 - 127 minutes)

Parameter 9, Parameter Size 2. Meter Report Interval.
The parameter defines the report interval for Power Metering.

VALUE	DESCRIPTION
0	Disabled
30 - 32 767	Duration in seconds (30 - 32 767. Default is 60)

Parameter 10, Parameter Size 1. Power restore level.
The parameter defines the initial dimming level after power loss.

VALUE	DESCRIPTION
1 - 99	1% - 99% Default is 50 (50%)

17. COMMAND CLASSES

Supported Command Classes

The following table lists all Command Classes supported by the Z-Wave Device. The device supports both S0, S2 Authenticated security and S2 Unauthenticated security.

	INSECURE INCLUSION	INSECURE ON SECURE INCLUSION	SECURE ON SECURE INCLUSION
Association (version 2)	Yes		Yes
Association Group Information (version 1)	Yes		Yes
Multi Channel Association (version 3)	Yes		Yes
Version (version 3)	Yes		Yes
Configuration (version 3)	Yes		Yes
Manufacturer Specific (version 2)	Yes		Yes
Z-Wave Plus Information (version 2)	Yes	Yes	
Device Reset Locally (version 1)	Yes		Yes
Powerlevel (version 1)	Yes		Yes
Firmware Update (version 4)	Yes		Yes
Basic (version 2)	Yes		Yes
Supervision (version 1)	Yes	Yes	
Switch Binary (version 1)	Yes		Yes
Meter (version 3)	Yes		Yes
Switch Multilevel (version 4)	Yes		Yes
Central Scene (version 3)	Yes		Yes
Security (version 1)	Yes	Yes	
Security 2 (version 1)	Yes	Yes	
Transport Service (version 2)	Yes	Yes	

PRODUCT INFO Heatit Z-Dim

FEATURES

- Z-wave rotary dimmer
- Scene controller
- Dims:
 - LED
 - 230V halogen
 - Incandescent lightbulbs
 - Dimable LED-drivers
 - Electronic transformers
- Starts at 1VA and dims up to 200VA LED
- Trailing edge
- Multiway switching option
- Electronic thermal cutoff with automatic reset
- Firmware updates (OTA)
- Power metering
- Supports encryption mode: S0, S2 Authenticated Class, S2 Unauthenticated Class

This product is a security-enabled Z-Wave Plus product with encryption. The product must be used with a security-enabled Z-Wave primary controller to fully utilize the product.

TECHNICAL DATA

Protocol	Z-Wave, 868,4MHz
Chip	Z-Wave 500 chip
SDK	6.71.03
Rated voltage	230V AC 50Hz
Power	1VA - 200VA
Input current	0,9A
Controls	Push and rotary dimmer
Operating temperature	-20°C - 40°C
Connection	Max. 2,5mm ²
Flush mounting depth	15mm
IP Code	IP 20
Size (LxWxH)	84 x 84 x 43mm
Approvals	Z-Wave Plus CE EN 55015/A2: 2009, EN 61547:2009 EN 61000-3-2/A2:2009 EN 61000-3-3:2008 EN 60669-2-1/A12:2010 EN 60669-1:A2:2008 EMC 2014/30/EU, RoHS 2011/65/EU LVD 2014/35/EU

Controlled Command Classes

- Multilevel Switch (version 4)
- Meter (version 3)
- Central Scene (version 3)
- Binary Switch (version 1)

Supported Command Classes

- Association (version 2)
- Association Group Information (version 1)
- Binary Switch (version 1)
- Multi Channel Association (version 3)
- Z-Wave Plus Information (version 2)
- Supervision (version 1)
- Switch Multilevel (version 4)
- Security (version 1)
- Security 2 (version 1)

Heatit Controls AB can not be held liable for typographical errors, other errors or omissions in our information.

Product specifications may change without further notice.

All electrical installations must be carried out by a licensed electrician.

The product must be installed in accordance with national building codes and our installers manual.



ART. NO.	PRODUCT	Z-WAVE FREQUENCY
14 444 44	Heatit Z-Dim 200VA - Z-Wave rotary dimmer	EU 868,4MHz