

HEATIT Z-WAVE

Firmware 1.8
01.07.2019

Installers manual



IMPORTANT

PLEASE READ THIS BEFORE INSTALLATION

This thermostat is tested and certified by Pepper One GmbH according to the requirements put forward by the Z-Wave Alliance. This is a Z-wave Plus product with the 500 series chip. If the product does not work with your gateway, then the gateway manufacturer has not made an integration or implemented such a thermostat with their gateway. We do not give any guarantee towards integration.

PRINCIPLES FOR REGULATION

The Heatit Z-Wave is designed for controlling electrical heating cables and electrical radiators/convectors. The thermostat has built in temperature sensors and has 3 algorithms for temperature compensation.

After you have set the temperature, the thermostat will use a hysteresis to regulate the temperature. The hysteresis is adjustable.

TEMPERATURE SHOWN IN DISPLAY

The temperature shown in the display is the actual temperature for floor sensor and the external room sensor. You are able to calibrate the sensor values.

When using the built in room sensor, the temperature shown is the set point. When using the built in sensor, the thermostat can seem somewhat inaccurate. This is due to heat generation inside the thermostat, draft and other external influences.

If the thermostat is to be used with waterbased heating systems, you have to use an external sensor.

Z-WAVE THERMOSTAT - SETUP

This manual describes the most essential functions and technical specifications of the thermostat.

These instructions help the user to control the thermostat, and the electrician to install and setup the thermostat.

INSTALLATION

Installation must be done by a qualified electrical installer in accordance with the National Building codes. Before installation, disconnect any power to the thermostat's mains. During installation of the thermostat, power to the thermostat must be disconnected AT ALL TIMES!

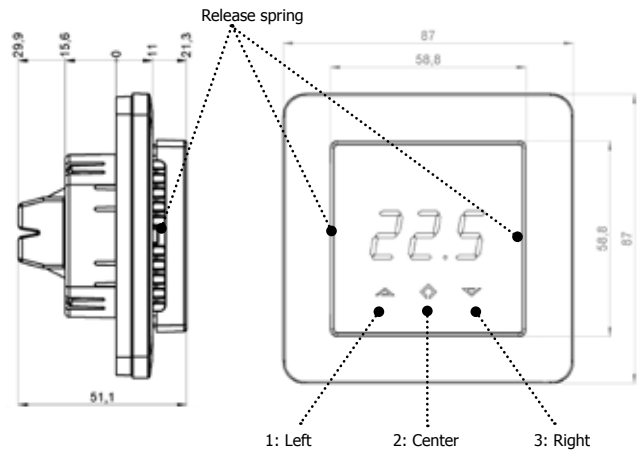

Use e.g. a small slotted screwdriver. Start by carefully removing the front cover by pushing the release springs. The front cover and the frame can now be removed.

Now connect the wires to the thermostat's terminals:
Use 1,5mm² or 2,5mm² according to load.

HEATING (N)	Heating cable connection (Neutral)
N	Power connection (Neutral) 230V
L	Power connection (Live) 230V
HEATING (L)	Heating cable connection (Live)
PILOT	230V pilot signal (ECO temp)

FLOOR SENSOR NTC type (10, 12, 15, 22, 33 or 47kΩ).
Default 10kΩ.

EXTERNAL SENSOR NTC type (10, 12, 15, 22, 33 or 47kΩ).
Default 10kΩ.

Next, position the thermostat and fasten it onto the wall's mounting box using 2-4 screws. Position the frame, then position and carefully press the front cover until it snaps in place. Check that the front cover has snapped in place properly on both left and right side. The front cover should now be firmly fixed on all sides.

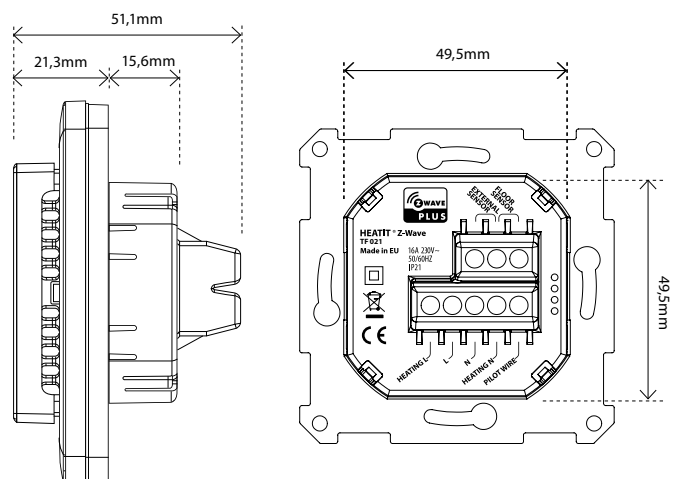

NOTE! Top cover has to be installed when the thermostat is connected to mains. The thermostat is not SELV product. All voltage parts are considered as 230VAC.

STARTUP

AFTER CONNECTING THE POWER TO THE THERMOSTAT FOR THE FIRST TIME, ALL PARAMETERS WILL HAVE DEFAULT SETTINGS.

CONTROL

The thermostat is controlled by three touch sensitive capacitive buttons.

You only need to touch lightly to activate the buttons.

1: Left (Up)

2: Center (Confirm)

3: Right (Down)

INCLUSION/EXCLUSION

To include the thermostat to your home automation gateway, press Center (confirm) for 10 seconds.

The display will show OFF. Press Right (down) 4 times till you see Con in the display. Now start add device in your home automation software. Start inclusion mode by pressing Center (confirm) for approximately 2 seconds. The inclusion/exclusion icon will appear in the display. Confirmation will show Inc/EcL in the display. If inclusion fails, Err (error) will appear. Leave programming mode by choosing ESC in menu.

Your thermostat is ready for use with default settings.

PROGRAMMING YOUR THERMOSTAT

To activate the programming mode, press Center (confirm) for 10 seconds. Now the display will show OFF.

Now you are in programming mode. To scroll up and down in the menu use button 1 and 3 (left and right) to navigate.

To enter submenu press Center (confirm). Always confirm your setting by pressing Center (confirm) for 2 seconds.

Menu:

OFF Turns the thermostat off.

Sensors:

1. **A** Choice of sensors

Depending on your choice of sensors, the menu will change.

2. **SEn** Select the right Ohm value for your external/floor sensor.
NTC type (10, 12, 15, 22, 33 or 47kΩ). Default 10kΩ.

3. **CAE** Calibration for external sensor.

CAF Calibration for floor sensor.

CAR Calibration for room sensor.

4. **br1** Brightness of display can be adjusted in this menu.

5. **Con** Activation of inclusion/exclusion mode.

6. **diF** Hysteresis.

7. **ALo** Setting lowest allowed temperature (limitation).
(Airsensor)

AHi Setting highest allowed temperature (limitation).
(Airsensor)

FLo Setting lowest allowed temperature (limitation).
(Floor sensor)

FHi Setting highest allowed temperature (limitation).
(Floor sensor)

PLo Setting lowest allowed power regulator mode.

8. **HEA** Switch between heating and cooling function.

ESC Escape – exit programming menu.

PRODUCT INFO Heatit Z-Wave

FEATURES

- Floor sensor
- Built in room sensor
- External room sensor
- Temperature limiter
- Power regulator
- Z-Wave Plus chip, 500 series
- Weekly program via gateway
- Setback mode via gateway or pilot wire
- LED-diode
- Can be used in connection with different NTC-sensors
- Lock mode/child lock
- Calibration
- 8 associations

TECHNICAL DATA

Protocol	Z-Wave, 868,4 MHz
Rated voltage	230V 50/60Hz
Max load	3600W (resistive load) 750W self-limiting heating cable
Max current	16A
Power consumption	1,5W
Min/max installation temp.	-20°C - 40°C
Min/max operating temp.	5°C - 40°C
Temperature intervals	Floor sensor 5°C - 40°C External room sensor 5°C - 40°C
Hysteresis	0,3°C - 3,0°C (default 0,5°C)
Switch	Single-pole switch
Sensor values	0°C 29,1 kOhm 10°C 18,6 kOhm 15°C 15,1 kOhm 20°C 12,2 kOhm 25°C 10,0 kOhm
IP Class	IP 21
Approvals	CE Z-Wave Plus EN 60730-1, EN 60730-2-9 EMC 2014/30/EU, RoHS 2011/65/EU LVD 2014/35/EU

The thermostat is designed for electrical heating.

ART. NO.	PRODUCT	COLOR	Z-WAVE FREQUENCY
54 304 99	Heatit Z-Wave thermostat 3600W 16A	White RAL 9003	EU 868,4MHz
54 304 46	Plastic kit for Heatit (front and frame)	Black RAL 9011	
54 301 07	Floor sensor Ø4mm 3 meters NTC 10 kΩ		
54 301 08	Floor sensor Ø3mm 6 meters NTC 10 kΩ		
54 301 27	External enclosed sensor IP 20/54		
54 304 97	Cable for software update on thermostat		

1. CHOICE OF SENSOR

The thermostat has a range of choices when it comes to sensors. To get to the menu you have to press Center (confirm) for 10 seconds, then press Right (down) once and an A shows in the display. Then press Center (confirm) again and you can choose one of these modes, while moving up and down with buttons Left or Right.

- F** Floor sensor
- A** Internal room sensor
- AF** Internal room sensor + Floor sensor
- A2** External room sensor
- P** Power regulator
- FP** Floor sensor + Power regulator
- A2F** External room sensor + Floor sensor

When you have decided on the sensor mode you want to use, press the Center (confirm) button. If you choose F or AF without having a floor sensor connected, Er4 will be shown in the display. If you choose A2 or A2F and there is no external sensor installed, Er5 will be displayed on the screen.

In power regulator mode the thermostat regulates the power consumption by switching on and switching off in time intervals. Switch-on and switch-off is done according to a time proportional control cycle of 30 minutes. This means that the heating element is switched on and off in a pulse/pause interval. This functionality is not supported in Z-Wave.

NOTE: Wooden floors require that a floor sensor is connected in order to limit the floor temperature to a maximum of 27°C (in accordance with specifications from most wooden floor manufacturers).

2. SELECT THE RIGHT OHM VALUE FOR YOUR EXTERNAL/ FLOOR SENSOR

The following values are available: NTC type (10, 12, 15, 22, 33 or 47kΩ). Default 10kΩ. The function is only active when an external sensor is connected. Confirm with Center (confirm) button.

3. CALIBRATION

In this mode you are able to adjust the displayed temperature. If the thermostat of some reason (or sensor) is not calibrated properly you are able to make minor changes to the temperature. You are able to raise/lower the set point by up to 4°C. Confirm with Center (confirm) button.

This function is only available for the floor sensor and external room sensor. When calibrating the room sensor, only the setpoint is changed. The display will not change.

4. BRIGHTNESS

Use Left and Right (up and down) button to adjust the brightness between 0-9. Confirm with Center (confirm) button.

5. INCLUSION/EXCLUSION

To include the thermostat to your home automation gateway, press Center (confirm) button for 10 seconds. The display will show OFF. Press Right (down) 4 times till you see Con in the display.

Now start add device in your home automation software. Start inclusion mode by pressing Center (confirm) button for approximately 2 seconds. The inclusion/exclusion icon will appear in the display. Confirmation will show Inc/EcL in the display. If inclusion fails, Err (error) will appear.

6. HYSTERESIS (DIF)

In this mode you are able to make changes to the hysteresis in the thermostat. This means that you can change the hysteresis from 0,3°C up to max 3,0°C. Confirm with Center (confirm) button. Default setting is 0,5°C. When using a waterbased heating, the recommended hysteresis is a minimum of 1,0°C.

7. MIN/MAX TEMPERATURE SETTINGS

- FLO Min Floor temperature
 - FHI Max Floor temperature
 - ALO Min Air/room temperature
 - AHI Max Air/room temperature
 - PLo Min temperature in Power Reg Mode
- Confirm with Center (confirm)

8. HEA Choose whether the thermostat is to be used for heating or cooling.

ESC Leaving programming mode. Confirm with Center (confirm) button.

9. STANDBY AND MAIN SCREEN

When the thermostat remains untouched for a while, it will automatically go to standby screen. Standby screen shows the temperature in the room or floor if the thermostat is connected to external sensors. By pressing Left or Right (up or down) button the setpoint will be shown in the display. If the internal room sensor is used, the thermostat display shows the setpoint.

10. DISPLAY ON/OFF - DON/DOF

Activate by pressing Left and Center (up and confirm) button for 10 seconds. The display light is temporarily activated if one of the buttons is pushed.

In case doF is activated, the screen will be blank (can be used if installed where people are sensitive to the light of the display). A very nice feature when used in a bedroom. When touching the display, the screen lights up.

11. CHILDLCK - LOC

By pressing Left and Right (up and down) buttons for 10 seconds, child lock will be activated and no changes can be made. Trying to make changes causes the LOC text to appear in the display. Child lock is deactivated by pressing Left and Right (up and down) buttons for 10 seconds. OPn will appear in the display.

12. FACTORY RESET - RES

By pressing buttons Right and Center (down and confirm) for 20 seconds, the thermostat will perform a complete factory reset. NB! Please use this procedure only when the primary controller/gateway is missing or otherwise inoperable.

13. CO/ECO MODE

The thermostat has 2 main programs, CO – comfort mode and ECO - economy mode. When Center (confirm) button is pushed for 2 seconds you switch between the 2 modes. You would normally have 2 different set-points for the different modes.

CO – mode: Is used for normal use. Example: 21°C.

ECO – mode: Is a setback mode that you can use if the thermostat is installed in a room or a house that is rarely used.

The ECO-mode can also be activated by the pilot wire if this is connected. Example: 18°C.

Some gateways also support switching between CO/ECO mode. In most circumstances, the CO/ECO function can be regarded as a home/away function.

14. COMMAND CLASSES

In order to run some schedule or week program, the primary controller/gateway should be responsible for controlling the thermostat using those selected command classes.

Classes:

GENERIC_TYPE_THERMOSTAT

SPECIFIC_TYPE_SETPOINT_THERMOSTAT

COMMAND_CLASS_BASIC

COMMAND_CLASS_THERMOSTAT_SETPOINT_V3

COMMAND_CLASS_THERMOSTAT_SETBACK

COMMAND_CLASS_SENSOR_MULTILEVEL

COMMAND_CLASS_VERSION

COMMAND_CLASS_MANUFACTURER_SPECIFIC

COMMAND_CLASS_ASSOCIATION

+ All other mandatory classes for selected device type

COMMAND_CLASS_CONFIGURATION_V2

Supports parameter numbers from 1 to 12 (if cooling enabled, from 1 to 13). Accepts byte sizes 1.2 and 4 bytes, but it is recommended to use 2-byte parameters in order get access to the whole temperature range.

15. ERROR CODES

- Er1: Internal error
- Er2: Z-Wave error
- Er3: Internal error
- Er4: Floor sensor error
- Er5: External sensor error

If you have chosen F or AF sensor mode without having a floor sensor connected, Er4 will be shown in the display. If you have chosen A2 or A2F, and there is no external sensors installed, Er5 will be shown in the display. If the Er1, Er2 or Er3 error codes are shown, contact your local dealer or Thermo-Floor AS.

PARAMETER	DESCRIPTION	RANGE	DEFAULT	WHAT IF VALUE OUT OF RANGE:
1	Operation mode	0x00 OFF 0x01 HEAT (0x02 COOL) 0x0B ENERGY SAVE HEAT	0x01 HEAT	Ignored
2	Sensor mode	0: F-mode 1: A-mode 2: AF-mode 3: A2-mode 4: P-mode 5: FP-mode	1: A	Ignored
3	Floor sensor type	0: 10k NTC 1: 12k NTC 2: 15k NTC 3: 22k NTC 4: 33k NTC 5: 47k NTC	0: 10k NTC	Ignored
4	DIFF I. Temperature control Hysteresis	3-30 (0,3°C 3,0°C)	5: 0.5°C	Ignored
5	FLo, Floor min limit	50-400 (5,0°C 40,0°C)	50: 5.0°C	Ignored
6	FHi, Floor max limit	50-400 (5,0°C 40,0°C)	400: 40.0°C	Ignored
7	ALo, Air min limit	50-400 (5,0°C 40,0°C)	50: 5.0°C	Ignored
8	AHi, Air max limit	50-400 (5,0°C 40,0°C)	400: 40.0°C	Ignored
9	PLo, FP-mode P setting	0-9	0	Ignored
10	CO mode setpoint	50-400 (5,0°C 40,0°C)	210: 21.0°C	Ignored
11	ECO mode setpoint	50-400 (5,0°C 40,0°C)	180: 18.0°C	Ignored
12	P setting	0-10	2	Ignored
13 (only if cooling enabled)	COOL setpoint	50-400 (5,0°C 40,0°C)	210: 21.0°C	Ignored

Thermo-Floor AS can not be held liable for typographical errors, other errors or omissions in our information.

Product specifications may change without further notice.

All electrical installations must be carried out by a licensed electrician.

The product must be installed in accordance with national building codes and our installers manual.