

HEATIT LEAKAGE STOPPER

Installers manual

Firmware 5.3

01.06.2021

Ver 2021-B



TABLE OF CONTENT

1. Product description
2. Statement regarding products from multiple manufacturers
3. Behaviour within the Z-Wave™ Network
4. Calibration
5. Prepare for installation / Reset
 - 5.1 Factory Reset
6. Installation
7. Add/Remove
 - 7.1 Method 1: Standard (Manual)
 - 7.2 Method 2: SmartStart (Automatic)
 - 7.3 Remove
8. Operating the device
 - 8.1 Button features
 - 8.2 Local or remote open and close of the valve
 - 8.3 Local alarm
 - 8.4 Local sensors
9. Quick trouble shooting
10. Node Information Frame
11. Security
12. Association - one device controls other devices
 - 12.1 Association Groups
13. Configuration Parameters
14. Technical Information

1. PRODUCT DESCRIPTION

The Heatit Leakage Stopper is a motor to retrofit existing and installed ball valves into smart water controlling devices. The motor is powered by a 12V external power supply or - optionally - a battery block. The adjustable clamps allow for mounting the device even in complex pipe installations, and the patented motor coupling ensures easy installation and precise long-term operation. The device can operate in difficult environmental conditions, even submerged in water, and supports a direct connection of one additional local water sensor pad via cable.

The device can operate in two modes:

Stand-Alone No further wireless connectivity is needed. A single click of the button opens and closes the valve. Clicking the button during open or close operation stops the movement. The next click will continue the operation. Escaping water is detected by the external sensor pad and the valve it shut off accordingly. The button on the device allows cancelling the alarm. A device in factory reset state operates in stand-alone mode without further configuration.

Z-Wave Network Mode The device is added to a Z-Wave network as Z-Wave Binary Switch Device. Adding can be done by using SmartStart or manual Z-Wave inclusion. All functions of the Stand-Alone mode remain active. Leakage or temperature alarms are forwarded to the Z-Wave gateway and other Z-Wave device are able to control the motor.

2. STATEMENT REGARDING PRODUCTS FROM MULTIPLE MANUFACTURERS

Please read this before installation

This device may be used with all devices certified with the Z-Wave Plus™ certificate and should be compatible with such devices produced by any manufacturer. Every primary controller is different depending on the manufacturer, their target audience and intended use/application. Please review the functionalities implemented by the primary controller you intend to use with our Z-Wave Plus certified device to ensure that it provides the necessary controls to take full advantage of our product's capabilities.

3. BEHAVIOUR WITHIN THE Z-WAVE™ NETWORK

This device may be operated within any Z-Wave network with Z-Wave-certified devices from other manufacturers. All non-battery-operated nodes within the network will act as repeaters regardless of manufacturer to increase the reliability of the network. On delivery, the device does not belong to any Z-Wave network.

The device needs to be added to an existing network to communicate with the other devices within it. Devices may also be removed from a network. The add/remove processes are initiated by the primary controller of the Z-Wave network.



heatit
CONTROLS

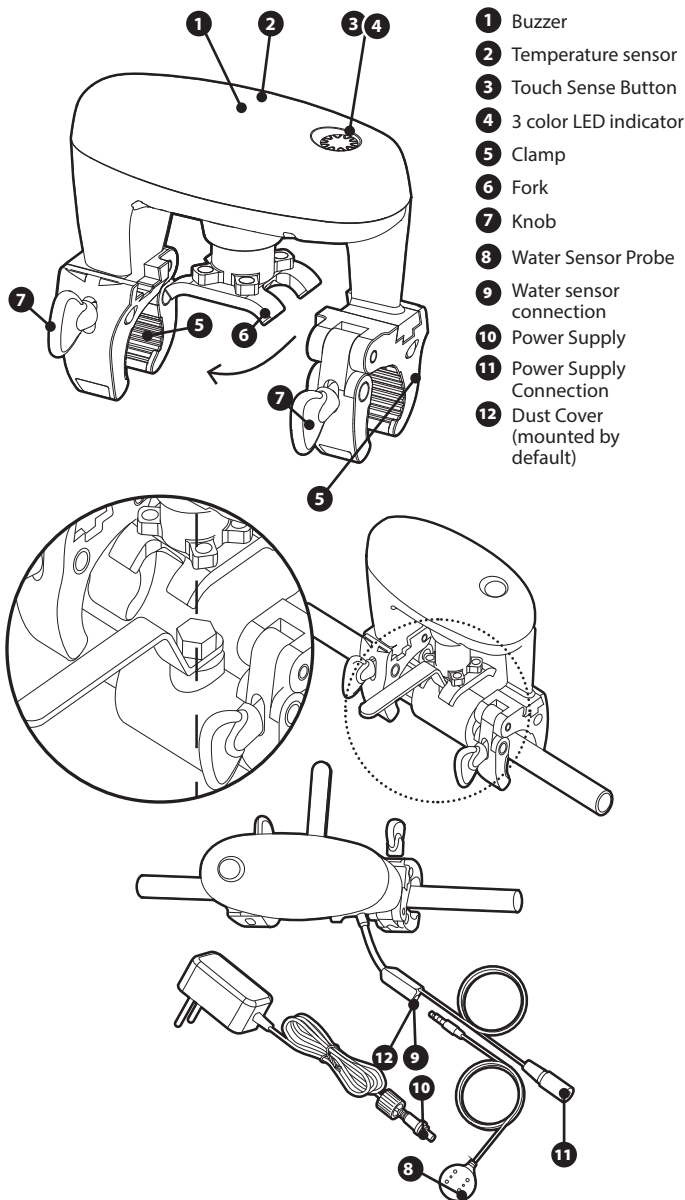

4. CALIBRATION

The Heatit Leakage Stopper is able to both measure the rotation angle and detect the end positions of the handle. It can therefore gently reach the end positions to avoid any friction and unneeded mechanical stress. Whenever the device is powered or repowered it will do a calibration run first. To start the calibration just push the button once. You will see some movement of the handle and after 10-20 seconds the device is ready to operate.

Calibration requires that the Heatit Leakage Stopper is mounted to a ball valve. The device will detect if no valve is present and stop calibration. In this case the operation of the handle (both by button and by wireless command) is disabled.

5. PREPARE FOR INSTALLATION / RESET

In order to add a Z-Wave device to a network, it must be in factory default state. Please make sure to reset the device to factory default. You can do this by performing an exclusion operation as described in this manual. Every Z-Wave controller is able to perform this operation, however it is recommended to use the primary controller of the previous network to make sure the device is removed properly from that network.

5.1 Factory Reset

Keep the button pressed for 10 seconds. Then click the button 5 times. The yellow LED will light up to confirm factory reset.

NB! Please use this procedure only when the primary controller/gateway is missing or otherwise inoperable.

6. INSTALLATION

1. Make sure the power is disconnected.
2. Choose the right size of the fork according to the size of the valve handle.
3. Make sure the two tightening knobs **7** and the valve handle face in the same direction (The handle must have clearance to move)
4. Tighten clamps **5** manually while holding down the Heatit Leakage Stopper.
5. If needed – unplug the dust cover **12** and connect the local Water Sensor Probe **8 9**
6. Connect the DC Power Adapter **10** to the power wire coming from the Heatit Leakage Stopper and tighten the water seal **11**.
7. Plug the power adaptor into a 230 V power socket.

7. ADD/REMOVE

The primary controller/gateway has a mode for adding or removing devices. Please refer to your primary controller manual on how to set the primary controller in add/remove mode. The device may only be added or removed from the network if the primary controller is in add/remove mode.

On delivery, the device does not belong to any Z-Wave network. The device can be added to an existing network or used in standalone mode to communicate with the devices of this network.

There are two ways to add the device to a Z-Wave network:

7.1 Method 1: Standard (Manual)

When using manual Z-Wave inclusion, triple click the button. Success is indicated by a green LED blinking for one second plus two short beeps by the buzzer.

7.2 Method 2: SmartStart (Automatic)

SmartStart enabled products may be added to a Z-Wave network by scanning the Z-Wave QR-Code on the product if your primary controller supports SmartStart inclusion. No further action is required and the SmartStart product will be added automatically after being powered on within range of the primary controller.

The QR-Code is needed when including a device using S2 security or SmartStart. The DSK can be found in the QR-Code and is located on the product. When using SmartStart just scan the QR code on your device.

7.3 Remove

Triple click the button. Success is indicated by a green LED blinking for one second plus two short beeps by the buzzer. When the device is removed from the network, it will NOT revert to factory settings.

8. OPERATING THE DEVICE

8.1 Button features

The device has one single button with a three color LED built in. Depending on the chosen action, you may click on the button or push

and hold the button for a few seconds. The Heatit Leakage Stopper will help you count out the seconds by beeping every second.

The Heatit Leakage Stopper is designed for outdoor use. To prevent misreadings caused by rain etc. users can use the Touch Sense Button Keylock function. Once disabled the only accepted operation of the button is reactivation. The operation of the Touch Sense Button can also be enabled/disabled using Z-Wave configuration parameter #67.

8.2 Local or remote open and close of the valve

A single click on the button starts the opening or closing action. Clicking the button when the device is mid-action stops the movement. Another click of the button resumes operation. (Please note that first operation of valve after power on will always cause calibration. Refer to chapter 'calibration' for more details.)

Z-Wave commands allow opening and closing of the valve using ON/OFF commands.

8.3 Local alarm

When the local sensor probe is attached and detects water, it will set off an alarm. The alarm is reported to a Z-Wave controller – when in Z-Wave network mode - and it causes the valve to close. The alarm will be indicated by the LED flashing red and the sound from the buzzer. You will not be able to operate the valve until the alarm has been reset.

To reset the alarm, click twice on the button (this will stop the buzzer and the LED will flash green) and then keep the button pressed for two seconds (count two beeps). Three green flashes of the LED confirms the resetting of the alarm.

8.4 Local sensors

The device has built-in sensors that send sensor values to the Z-Wave gateway when connected.

- Temperature Sensor Value
- Temperature Overheat Alarm (0x04-0x02, heat detected)
- External Sensor Probe
- Water Leak Alarm (0x05- 0x02 leak detected)

9. QUICK TROUBLESHOOTING

Here are a few hints for network installation if things don't work as expected.

- Make sure the device is in factory reset state before including. If in doubt, remove it from the network before adding it to the network again.
- If inclusion still fails, check if both devices use the same frequency.
- Remove all dead devices from associations. Otherwise you will see severe delays.
- Make sure to have enough mains powered devices with Z-Wave mesh functionality in order to provide optimal signal range.

10. NODE INFORMATION FRAME

The node information frame is the "business card" of a Z-Wave device. It contains information about the device type and its technical features. The add and remove procedure of the device is confirmed by sending out a node information frame. Besides this, it may be necessary for certain network operations to send out a node information frame.

11. SECURITY

S2 security enhances Z-Wave Plus with an additional layer of AES

128-bit encryption of the wireless Z-Wave communication to prevent hacking and man-in-middle attacks on the home network. This device supports S2 and has a Z-Wave DSK QR-Code label that may be used when the module is added to the Z-Wave home network. The primary controller will ask for a 5-digit code, which can be found underneath the QR-Code. The primary controller will then ask you to confirm the rest of the code that is contained in the QR-Code.

12. ASSOCIATIONS - ONE DEVICE CONTROLS OTHER DEVICES

Z-Wave devices interact with other Z-Wave devices. The relationship between one device controlling another device is called an association. In order to control a subordinate device, the controlling device needs to maintain a list of devices that will receive controlling commands. These lists are called "Association groups". They are always related to the specific event triggered (e.g., sensor reports). In case the event is triggered, all devices stored in the respective association group will receive a joint wireless command.

12.1 Association Groups

NUMBER	MAX NODES	DESCRIPTION
1	5	Lifeline. All alarms and status information that shall be sent to the gateway
2	5	Switch Devices when Water Valve is operated (either local or by sensor or by wireless command)
3	5	Switch Devices when water leak was detected
4	5	Switch Devices when temperature raise above threshold
5	5	Switch Devices when temperature falls below threshold

13. CONFIGURATION PARAMETERS

The following table lists all Command Classes supported by the Z-Wave device. The device supports S0, S2 Authenticated security and S2 Unauthenticated security.

Z-Wave products are supposed to work out of the box after inclusion. Some device configuration may, however, alter the functionality to better serve user needs or unlock further enhanced features. All of the parameters listed in the following table do not feature altering capabilities, advanced or read only flag.

Parameter 17: Water Valve Report Value

This parameter defines how the water valve position is reported.
Size: 1 byte, Default Value: 1

VALUE	DESCRIPTION
0	Normal
1	Inverted

Parameter 18: Command Sent into Association Group 2 on ON

Defines what BASIC command Value to send into Association Group 2.
Size: 1 byte, Default value: 1

VALUE	DESCRIPTION
0	Disabled
1	Enabled Basic On (0xff)
2	Enabled, Basic Off (0x00)

Parameter 19: Command Sent into Association Group 2 on OFF

Defines what BASIC command Value to send into Association Group 2.
Size: 1 byte, Default value: 2

VALUE	DESCRIPTION
0	Disabled
1	Enabled Basic On (0xff)
2	Enabled, Basic Off (0x00)

Parameter 33: Temperature Sensor Report

Defines if and how a temperature value is reported.

Size: 1 byte, Default value: 2

VALUE	DESCRIPTION
0	Disabled
1	Enabled Basic On (0xff)
2	Enabled, Basic Off (0x00)

Parameter 34: Temperature Sensor Report Threshold

Defines the change in temperature value to cause unsolicited sending of a report.

Size: 2 byte, Default value: 1

VALUE	DESCRIPTION
0x0000-0x00ff	Value in Celsius (Example: 0x0002 = 2°C)

Parameter 35: Temperature Sensor Report Offset

Defines a temperature offset for the reported temperature. This parameter can be used to compensate for certain temperature deviations.

Size: 2 byte, Default value: 0

VALUE	DESCRIPTION
0x0000-0x00ff	Positive Deviation in Celsius (e.g. 0x0002 = +2°C)
0x1000-0x10ff	Negative Deviation in Celsius (e.g. 0x1002 = -2°C)

Parameter 36: Temperature Overheat Trigger

Sets the temperature to trigger the overheat alarm.

Size: 2 byte, Default value: 40

VALUE	DESCRIPTION
0x0000-0x00ff	Value in Celsius (example: 0x0002 = 2°C)

Parameter 37: Temperature Overheat Reset Trigger Value

Sets the temperature to reset the overheat alarm.

Size: 2 byte, Default value: 40

VALUE	DESCRIPTION
0x0000-0x00ff	Value in Celsius (example: 0x0002 = 2°C)

Parameter 38: Temperature Overheat Action Value

Defines what BASIC command Value to send into Association Group 4.

Size: 1 byte, Default value: 0

VALUE	DESCRIPTION
0	Disabled
1	Enabled Basic On (0xff)
2	Enabled, Basic Off (0x00)

Parameter 39: Temperature Overheat Action Reset Value

Defines what BASIC command Value to send into Association Group 4.

Size: 1 byte, Default value: 0

VALUE	DESCRIPTION
0	Disabled
1	Enabled Basic On (0xff)
2	Enabled, Basic Off (0x00)

Parameter 40: Freeze Trigger Value

Sets the temperature threshold to cause a freeze alarm.

Size: 2 byte, Default value: 0

VALUE	DESCRIPTION
0x0000-0x00ff	Value in Celsius (example: 0x0002 = 2°C)

Parameter 41: Freeze Trigger Reset Value

Sets the temperature threshold to reset a freeze alarm.

Size: 2 byte, Default value: 40

VALUE	DESCRIPTION
0x0000-0x00ff	Value in Celsius (example: 0x0002 = 2°C)

Parameter 42: Freeze Valve Action

This parameter defines If detected freezing shall close the valve.

Size: 1 byte, Default value: 1

VALUE	DESCRIPTION
0	Disabled
1	Enabled

Parameter 43: Freeze Association Action Command

Defines what BASIC command Value to send into Association Group 5.

Size: 1 byte, Default value: 0

VALUE	DESCRIPTION
0	Disabled
1	Enabled Basic On (0xff)
2	Enabled, Basic Off (0x00)

Parameter 44: Freeze Association Reset Command

Defines what BASIC command Value to send into Association Group 5.

Size: 1 byte, Default value: 0

VALUE	DESCRIPTION
0	Disabled
1	Enabled Basic On (0xff)
2	Enabled, Basic Off (0x00)

Parameter 49: Leak Detection Command Value

Defines what BASIC command Value to send into Association Group 3.

Size: 1 byte, Default value: 1

VALUE	DESCRIPTION
0	Disabled
1	Enabled Basic On (0xff)
2	Enabled, Basic Off (0x00)

Parameter 50: Leak Detection Reset Command Value

Defines what BASIC command Value to send into Association Group 3.

Size: 1 byte, Default value: 2

VALUE	DESCRIPTION
0	Disabled
1	Enabled Basic On (0xff)
2	Enabled, Basic Off (0x00)

Parameter 51: Water Leak Detection Valve Control

Defines if the valve shall be closed when a water leak alarm occurs.

Size: 1 byte, Default value: 1

VALUE	DESCRIPTION
0	Disabled
1	Enabled

Parameter 65: Buzzer enable

Defines if built-in buzzer shall be active.

Size: 1 byte, Default value: 1

VALUE	DESCRIPTION
0	Disabled
1	Enabled

Parameter 66: LED Brightness Level

Defines the brightness level of LED in %.

Size: 1 byte, Default value: 0x50 (80%)

VALUE	DESCRIPTION
0x00-0x63	Brightness level 0%-99%

Parameter 67: Touch Sensor Key Lock

Defines if touch button is active.

Size: 1 byte, Default value: 1

VALUE	DESCRIPTION
0	Disabled
1	Enabled

Parameter 81: Notifications

Defines which notifications are active.

This parameter is a bitmap value, to choose which notifications you need to add up the values specified in the value field.

(Example in decimal: Overheat report (2) and Water Leak report (8): value 2+8=10)

Size: 1 byte, Default value: 0x0d

VALUE	DESCRIPTION
1 (bit 0)	Water Valve Report
2 (bit 1)	Overheat Report
4 (bit 2)	Freeze Report
8 (bit 3)	Water Leak

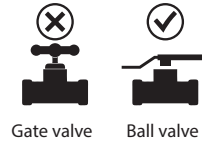
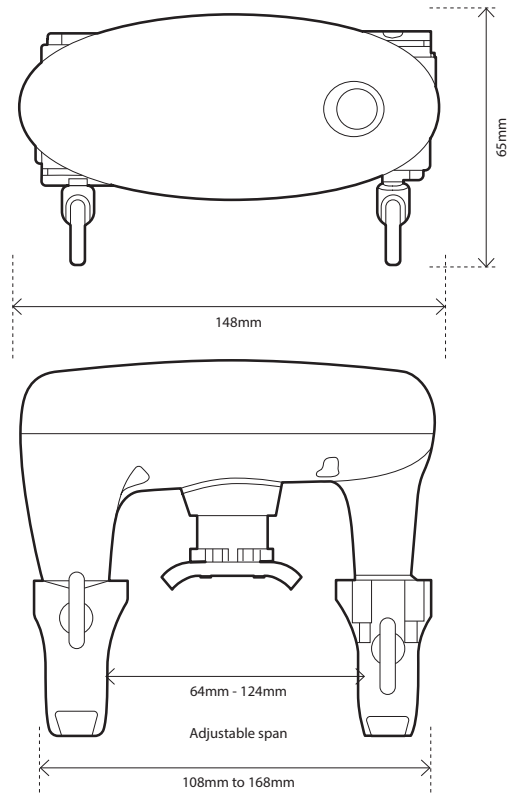

Gate valve

Ball valve

Check your valve type before installation. This unit is for ball valve installations only.

PRODUCT INFO Heatit Leakage Stopper

FEATURES

- Leakage stopper
- Fits standard ball valves (1/2" to 1 1/4" pipes)
- No tools needed for mounting
- Automatic valve exercise
- Temperature sensor
- Can be used standalone or through gateway
- Cabled moisture sensor
- Alternate wireless sensors
- Sintef certified
- TEK approved
- FG-approved
- SmartStart
- Support encryption modes S0, S2 Authenticated Class, S2 Unauthenticated Class

This product is a security-enabled Z-Wave Plus product with encryption. The product must be used with a security-enabled Z-Wave Controller in order to fully utilize the product.

TECHNICAL DATA

Protocol	Z-Wave Plus V2, 868.4MHz
Chip	Z-Wave 700 chip
Voltage	12V/1A (trafo to 230VAC)
Ambient temperature	-10°C to 50°C (-65°C to 100°C storage)
Range RF	Min. 60 meters
IP Code	IP 66
Pipe dimension	1/2" to 1 1/4"
Size (LxBxH)	148 x 65mm
Certification	Z-Wave Plus V2, CE, Sintef Certification

MAINTENANCE

The device is maintenance-free, but must never be covered.

ART. NO.	PRODUCT	COLOR	FREQUENCY
45 666 51	Heatit Leakage Stopper	White	EU 868.4MHz

The product is also available in other Z-Wave frequency versions on request.

DISPOSAL GUIDELINES

Do not dispose of electrical appliances as unsorted municipal waste, use separate collection facilities. Contact your local government for information regarding the collection systems available. If electrical appliances are disposed of in landfills or dumps, hazardous substances can leak into the groundwater and get into the food chain, damaging health and well-being.



Heatit Controls AB can not be held liable for typographical errors, other errors or omissions in our information. Product specifications may change without further notice. All electrical installations must be carried out by a licensed electrician. The product must be installed in accordance with national building codes and our installers manual.